

# TKB 4600S/E

| MODEL                     | TKB 4600S        |            |
|---------------------------|------------------|------------|
| UDŹWIG                    | 10 kg            |            |
| MAKS. PROMIEN ROBOCZY     | 1435 mm          |            |
| DOF                       | 6 mln            |            |
| WAGA                      | 175 kg           |            |
| MARKA REDUKTORA           | -                |            |
| MARKA SILNIKA             | RRRobotica Italy |            |
| MARKA NAPĘDU              | RRRobotica Italy |            |
| MOC ZNAMIONOWA            | 4.62 kw          |            |
| MAKSYMALNA PRĘDKOŚĆ       | J1               | 140°/s     |
|                           | J2               | 140°/s     |
|                           | J3               | 150°/s     |
|                           | J4               | 360°/s     |
| MAKSYMALNY OBSZAR ROBOCZY | J1               | ±175°      |
|                           | J2               | 85° ~ -35° |
|                           | J3               | 60° ~ -80° |
|                           | J4               | ±360°      |
| SPECYFIKACJA OCHRONNA     | 40               |            |
| PRECYZJA                  | ±0.08 mm         |            |
| TEMPERATURA PRACY         | 0~45°            |            |

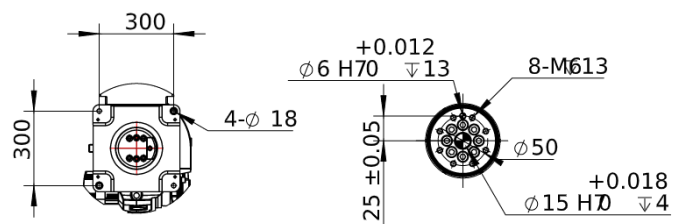
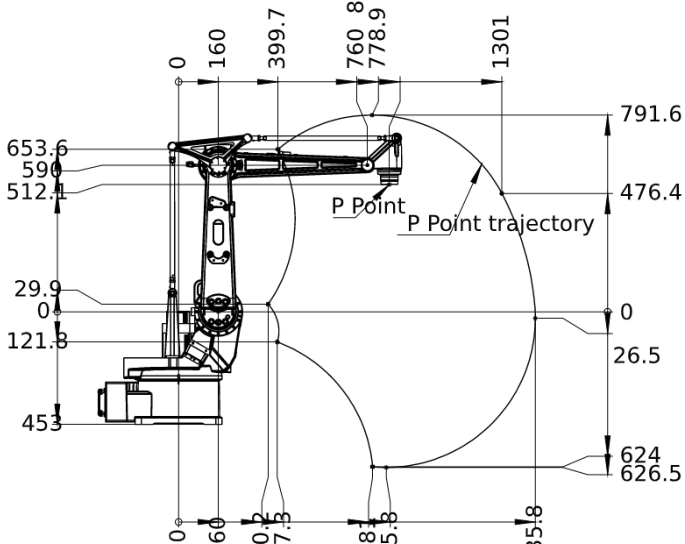
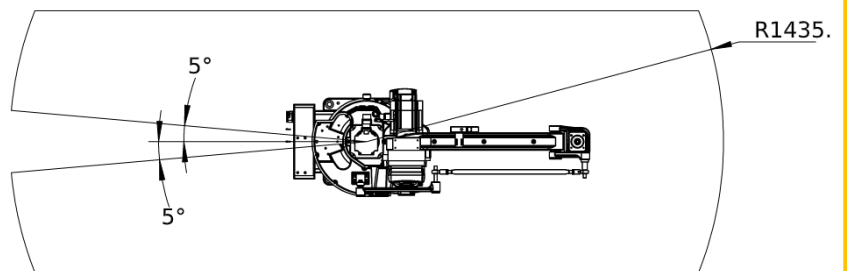
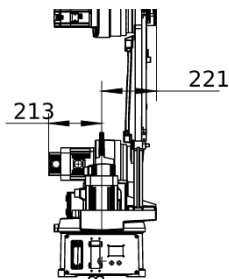
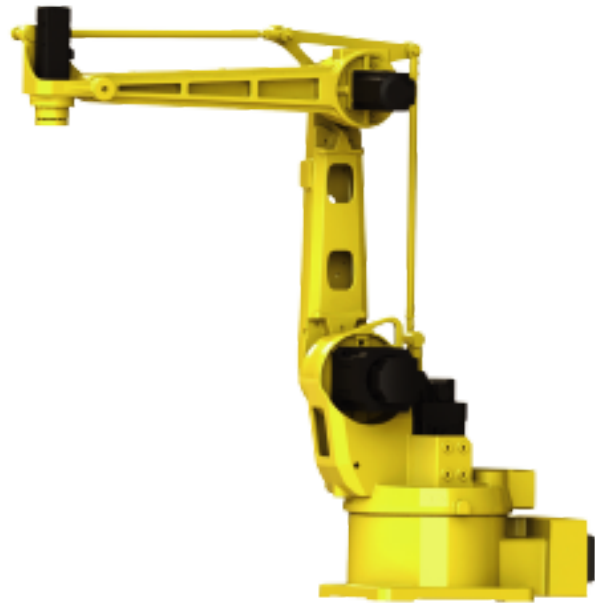

Base installation drawing

Flange installation drawing